

TraxMaxx Hydraulic Rail Drill
910204
Operating Manual



TraxMaxx Hydraulic Rail Drill

910204

Record of Changes

Rev No.	Date	Description of Changes
Rev 1	12.2020	Initial Release
Rev 1.1	5.2022	Add Rail Shoe Installation and Rail Shoe and Cutter Parts List
Rev 1.2	7.2022	Update Arbor Spindle Assembly and Parts List (pg 22)
Rev 1.3	1.2023	Update format and layout
Rev 1.4	3.2023	Update Footer and Contact Information Update Parts and Service page with contact information
Rev 1.5	10.2023	Update Technical Support & Service information

Table of Contents

Section 1: Overview and Safety	5
TraxMaxx Hydraulic Rail Drill Overview	5
Environmental Protection	5
Safety Information	5
Safety Terms	6
Machine Use and Safety Precautions	6
Section 2: Specifications and Installation.....	8
Specifications	8
Installation Instructions.....	9
Hose Requirements	9
Hose Types	9
Hydraulic Hose Recommendation	10
Hydraulic Fluid Recommendation	10
Tool Connecting Procedures	11
Disconnecting Hoses	11
Section 3: Tool Operation	12
Personal Protective Equipment	12
Pre-Operation.....	12
Coolant	12
Drill Operation	12
Rail Shoe Installation.....	14
Rail Shoe Parts List	15
Cutter Parts List	16
Section 4: Maintenance.....	17
Gearbox Oil Level	18
Determining the Problem Area	19
Troubleshooting.....	20
Troubleshooting Guide	20
Section 5: Parts and Service Support	22
Arbor Spindle Assembly and Parts List.....	24
Arbor / Spindle Drive Assembly and Parts List	25
Arbor / Spindle Drive Assembly Parts List.....	26
Arbor Spindle Feed Assembly and Parts List	27

Rail Clamp Assembly and Parts List.....	28
Section 6: Warranty Terms and Conditions	29

Section 1: Overview and Safety

TraxMaxx Hydraulic Rail Drill Overview

RRP designs and manufactures equipment primarily for the repair and new construction of rail and railroad tie track maintenance.

The RRP TraxMaxx Hydraulic Rail Drill is a quality product with unique features that make this the perfect solution for your entire rail drilling requirements.

- Easy to use and rugged design makes the TraxMaxx Hydraulic Rail Drill a cost-effective solution to drilling clean, accurately positioned holes in rail sections for bonds, and fishplates.
- Available in 1" to 1-1/2" (25 mm – 378 mm) diameters.

Do not use this machine for other than its intended purpose.

Please read these instructions when using this tool, which can only be used for the specified purpose. Failure to do so could result in personal injury or equipment damage. This instruction manual should be kept throughout the life of the tool.

The operator of this tool should:

- Have access to this operation instruction.
- Read and understand this operation instruction.

Environmental Protection



Comply with relevant national waste disposal laws and regulations. Waste electronic devices cannot be treated as household waste.

Equipment, accessories, and packaging shall be recyclable.



Do not throw the discarded equipment in trash cans.

Safety Information

For safe installation and operation of this equipment, carefully read and understand the contents of this manual. Improper operation, handling, or maintenance can result in equipment damage and personal injury.

Only trained and authorized personnel should be allowed to operate this machine. In addition, all personnel at the worksite should be aware of the safety concerns and their individual responsibilities prior to working with this machine.

Please read and comply with all the safety precautions in this manual **before** operating this machine. Your safety is at risk.

Safety Terms



DANGER indicates a hazardous operating procedure, practice, or condition. If the hazardous situation is not avoided death or serious injury will occur.



WARNING indicates a hazardous operating procedure, practice, or condition. If the hazardous situation is not avoided death or serious injury could occur.



CAUTION indicates a potentially hazardous operating procedure, practice, or condition. If the hazardous situation is not moderate or minor injury could occur.

Machine Use and Safety Precautions



Failure to follow safety precautions when operating this equipment can result in serious injury or death to the operator or other persons in the area.

Observe the following precautions whenever you are operating, working on or near this equipment.

Do not make any modifications without authorization or written approval from Racine Railroad Products. Replace all Racine Railroad Products and OEM parts with genuine Racine Railroad Products and OEM parts. Using non-OEM parts may compromise the safety of the machine.

Do not wear loose clothing, jewelry, radio belts, etc., when operating, working on or near this equipment. They can be caught in moving parts and may result in severe injury.

Always wear appropriate personal protective clothing when operating this equipment: e.g., orange safety vest, hard hat, safety glasses with side shields, hearing protection, steel-toed safety boots, leather gloves, dust respirator, etc.

Always lift heavy objects with the knees and legs, not the arms and back.

Always keep hands, arms, feet, head, clothing, etc., out of the operating area and away from all rotating or moving components when operating, working on or near this machine.

Always make sure that all guards, covers, belts, hoses, and operating components are in good working order and that all controls are in the appropriate position before starting the engine.

Always make sure that all safety equipment installed properly and are in good working order. Do not operate the machine until unsafe conditions have been corrected.

Always operate in a well-ventilated area and make sure that the air filters, air filter covers, and muffler are in good condition.

Always keep the machine clean and free of debris. Operate the machine in a safe and responsible manner. Exercise caution when fueling, working on or near rotating or moving components, hot components, and fuel systems. Be aware of potential fire hazards and prevent sparks, exhaust, etc., from starting fires on the machine and/or work area.

Always comply with all instructions provided on any decals or placards installed on the machine and with any relevant amplifying information provided in this manual or other general operating procedures.

Regularly inspect the machine and check that nuts and screws are tight.

Always disconnect the power source and make sure that all controls are in a safe position and install all appropriate locking and safety devices before doing any of the following:

- Lubricating
- Adjusting
- Installing Tooling
- Making Repairs
- Performing Service

If the machine is dropped, always thoroughly examine the machine for signs of damage and check that it functions correctly before trying to cut a hole.



Tools are not insulated for use on or near energized conductors. Use of these tools near energized conductors may lead to electrical shock, causing severe injury or death.

Do not use these tools near energized conductors without adequately insulating operator and surroundings.



Tool parts rotate at high speeds and can cause severe personal injury. Keep **all** body parts away from moving parts of the tool when connected to a hydraulic power source or during operation.



Operator must clear all bystanders from the work area when handling, starting, and operating a tool to avoid injury to bystanders.



Do not over-reach while using a tool. Loss of balance can cause serious personal injury or death. Move closer to work area and securely support yourself and your work. **Always keep proper footing and balance.**



Hydraulic fluid is under pressure.

Always depressurize the hydraulic system before connecting or disconnecting a tool to avoid serious injury from escaping fluid. If injury results from escaping hydraulic fluid, seek immediate medical attention to avoid serious bodily injury.



Hot hydraulic fluid.

Exposure to hot hydraulic fluid can cause severe burns. Do NOT connect or disconnect a tool while the hydraulic power source is running and/or the hydraulic fluid is hot.



Never lock a tool trigger in the power ON position. A tool locked ON can lead to serious injury or death

Section 2: Specifications and Installation

Specifications

Net Weight 46 lbs (20 kg)

Maximum hole cutting capacity diameter 1-3/8" (35 mm).

Arbor bore 3/4" (19 mm)

Hydraulic Motor

- VIVOLO 9.8CC Hydraulic Motor 9.88cm³/rev displacement
- 14 HP
- Maximum working pressure 190 bar

Engine Speed

- No load (arbor/spindle)..... 3,833 rpm
- No load (engine)..... 255 rpm

Compression Ratio..... 15:1

Maximum hand/arm vibration magnitude (measured at handle during operation in accordance with ISO 5349)

- 2.45 m/s²

Estimate of likely daily vibration exposure – Operation on 2 rails (24 holes @ 1 minute/hole)

- 0.87 m/s² A (8)

Average noise level during cutting at operator's ear position

- 81 dB(A)

Included Parts

- 3/16 Long Hex key
- 4 mm T-handle hex key
- 8 mm Hex key
- Coolant Feed Dispenser

Installation Instructions

Unpacking Instructions

Upon receiving your TraxMaxx Hydraulic Rail Drill promptly remove it from the shipping container. Always keep the top side of container up. Inspect unit for damage which may have incurred during shipping and report it to carrier for claim.

Tool Preparations

The TraxMaxx Hydraulic Rail Drill is ready for use after unpacking and no special preparation is required. If the tool is used in cold weather, preheat the hydraulic fluid by running the power source at low engine speed.

Fluid temperature should be at or above 50 °F / 10 °C (400-ssu / 82 centistroke) before use, when using recommended fluids. Using too thick of fluid may result in tool damage.



WARNING

Never stick foreign objects, fingers, or other extremities into the moving mechanism. Failure to follow these instructions may lead to severe personal injury or tool damage.

Hose Requirements

It is not often necessary or advisable to use long hoses. All hoses must have an oil resistant inner surface and an abrasion resistant outer surface. Each hose must have male pipe ends for most application.

Longer hoses can be used when necessary but can affect the operation of the tool due to resistance in the hose.

If small diameter or long hoses are used, or if restrictive fittings are connected to the supply and return ports, the pressure required to push the fluid through the system and back to the tank will be higher. This will reduce tool power.

Important: Oil should always flow from the male coupler through the female coupler.

Note: The pressure increases in uncoupled hoses left in the sun. This may make them difficult for them to connect. When possible after use, connect the free ends of the operating hoses together.

Hose Types

Hydraulic hose types authorized for use with the TraxMaxx Hydraulic Rail Drill are:

1. **Labeled and certified non-conductive.**

- This is the only hose authorized for use near electrical conductors.
- Constructed of thermoplastic or synthetic rubber inner tube, synthetic fiber braid reinforcement, and weather resistant thermoplastic or synthetic rubber cover.

2. **Wire braided** (conductive)

- This hose is conductive and must **never** be used near electrical conductors.
- Constructed of synthetic rubber inner tube, single or double wire braid reinforcement, and weather resistant synthetic rubber cover

3. **Fiber braided** (not certified or labeled non-conductive)

- This hose is conductive and must **never** be used near electrical conductors.
- Constructed of thermoplastic or synthetic rubber inner tube, synthetic fiber braid reinforcement, and weather resistant thermoplastic or synthetic rubber cover.

The rated working pressure of the hydraulic hose must be at least 175 bar (2500 psi).

Hydraulic Hose Recommendation

Hydraulic Hose Recommendation								
Flow Per Circuit		Length Each Hose		Use	Inside Diameter		SAE Spec Hose (Wire Braid)	SAE Spec Hose (Fiber Braid)
GPM	LPM	Feet	Meter		Inch	MM		
5 to 8	19 to 30	To 50	To 15	Both	1/2	13	SAE 100R1-8	100R7-8
5 to 8	19 to 30	51 to 100	15 to 30	Both	5/8	16	SAE 100R2-10	SAE 100R8-10
5 to 8	19 to 30	100 to 300	30 to 90	Pressure Return	5/8 3/4	16 19	SAE 100R2-10 SAE 100R1-12	SAE 100R8-10 SAE 100R7-12
9 to 12	34 to 45	To 50	To 15	Both	5/8	16	SAE 100R2-10	SAE 100R8-10
9 v 12	34 to 45	51 to 100	15 to 30	Pressure Return	5/8 3/4	16 19	SAE 100R2-10 SAE 100R3-12	SAE 100R8-10 SAE 100R7-12
9 to 12	24 to 45	100 to 200	30 to 60	Pressure Return	3/4 1	19 25.4	SAE 100R2-12 SAE 100R1-16	SAE 100R8-12 SAE100R7-16

The rated working pressure of the hydraulic hose must be at least 2500 psi / 173 bar.

Hydraulic Fluid Recommendation

Inspect hoses for cuts, crushing, leaks, or abrasion, which may be a safety hazard or reduce fluid flows.

The following fluids work well over a wide temperature range at startup, allow moisture to settle out, and resist biological growth likely in cool operating hydraulic circuits.

Others that meet or exceeds the specifications of these fluids may also be used.

Type	Hydraulic fluid
Amsoil	AWH ISO 32
Chevron	Rando HD Premium Oil MV ISO VG 32 Rando HDZ ISO 32
Gulf	Harmony AW ISO Multi-Grade 32
Mobil	DTE Oil Excel 32
Schaeffer	Dillex Supreme Hydraulic Fluid w/ Dynavis ISO 46.
Shell	Shell Tellus S2 VX 32
Sunoco	Sunvis 1032 HVI Hydraulic Oil

Tool Connecting Procedures

1. Stop the engine before connecting the tool and or hoses to the power unit, and when switching hoses or tools.
2. Turn the hydraulic on/off valve to the off position before starting the engine.

Make sure all hoses are connected for correct flow direction to and from the tool being used.

When routing hose in the work area, position them where personnel will not be at risk of tripping over them where vehicles can run over the hoses. Do not lay hose over sharp objects.



WARNING Pressurized fluid escaping from a damaged hose can penetrate the skin and be injected in the body causing injury or death.

Do not pull on hoses to drag the power unit or tool.

Connecting Hoses

1. Wipe quick couplers with a clean lint free cloth before connecting them.
2. Depressurize the system.
3. Allow system and hydraulic fluid to cool if too hot to handle.
4. Securely connect the return (tank "R") hose from the power source to the tool.
5. Securely connect the supply (pressure "P") hose from the power source to the tool.

It is recommended that you connect the return hoses first and disconnect last to minimize or avoid trapping pressure within the tool.

When connecting the quick couplers, the flow should run from male coupler to the female coupler. The female coupler on the tool is the inlet. Quick couplers are marked with a flow direction arrow.



WARNING Pressurized fluid escaping from a damaged hose can penetrate the skin and be injected in the body causing injury or death.

Do not pull on hoses to drag the power unit or tool.

Note: When possible, connect the free ends of uncoupled hoses to prevent build up in the hoses. The sun can also increase pressure in the hoses and make connecting them difficult.

Disconnecting Hoses

1. Stop the hydraulic power source.
2. Depressurize the system.
3. Allow system and hydraulic fluid to cool.
4. Disconnect the supply (pressure) hose from the power source (pressure port) from the tool (IN port).
5. Disconnect the return (tank) hose to the hydraulic power source (return port) from the tool (OUT port).
6. To prevent contamination, always install dust caps over the hydraulic ports of the tool when disconnected.

Section 3: Tool Operation

Personal Protective Equipment



Before operating this machine, make sure that all general safety precautions are observed, and that proper personal protective clothing is worn as described below.

At a minimum, operators should wear the following Personal Protective Equipment:

1. Safety Glasses
2. Hearing Protection
3. Hard Hat
4. High Visibility Safety Vest
5. Leather Work Gloves
6. Steel Toed Safety Shoes

Pre-Operation



Do not use a live conductor rail.

Eye and ear protection must be worn within 3 feet [1 meter] when the motor is running.

- Make sure the motor is switched OFF when changing cutters, working on the machine, or removing swarf. Failure to do so may result in personal injury.
- Always make sure the cutter is securely fastened.
- Should the cutter become fast in the work piece, switch off the motor immediately to prevent personal injury. Do not attempt to free the cutter by starting and stopping the motor. Failure to do so may result in personal injury.
- On completion of the cut, a slug will be ejected. DO NOT operate the machine if the ejected slug is not visible. Injury may occur.
- Remove adjusting keys and wrenches. Form the habit of checking to see that keys and adjusting wrenches are removed from the tool before turning it on.
- Secure the work where possible with clamps or vices to hold the work.

Coolant

Coolant is injected into the system through a pressurized coolant bottle.

1. Connect the coolant bottle to the machine through the connector.
2. Pressurize the bottle by pumping the coolant bottle's pump several times.
3. Regulate the flow using the stop tap. A quarter turn is usually sufficient.

Drill Operation

1. Select the appropriate cutter.
 - Insert the cutter's shank into the appropriate pilot.
 - Place the assembly, correctly aligning the drive flats, into the arbor bore.
 - Securely fasten the socket screws with the hexagon key.
2. Keep the inside of the cutter clear of swarf. It restricts the operating depth of the cutter.
3. Pressurize the coolant dispenser. Pump the handle until the relief valve extends and pump the handle 5 to 10 more times.
 - When the pressurized cutting fluid dispenser is connected to the coolant feed tube, the coolant is metered out by the pilot and is applied directly to the cutting edge.
 - To make sure the cutting fluid is correctly metered, press the pilot by slowly moving the cutter to touch the rail. Regulate the flow by adjusting the needle valve.
4. Feed the cutter through the rail using the feed handle arm.
 - When starting to cut a hole, apply light pressure until the cutter is introduced into the work surface.
5. Slightly increase the pressure while cutting the hole.
 - Excessive pressure is undesirable. It does not necessarily increase the speed of penetration and it may damage the cutter, greatly reducing the machine life.
 - Cutter breakage is usually caused by insecure clamping.
6. Once drilling is complete, immediately fully retract the cutter.

Rail Shoe Installation

Rail Shoe Mounting

1. Use the indicated threaded hole.
2. Position the rail shoe so the threaded hole is facing into the rail drill (see below).
3. Use the threaded screw to secure the rail shoe to the drill.

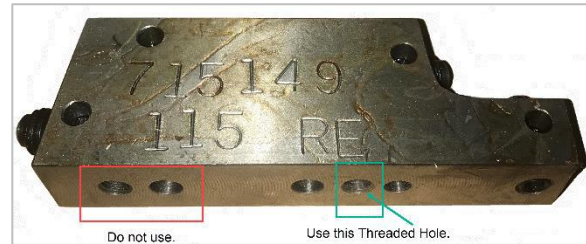

Rail Shoe

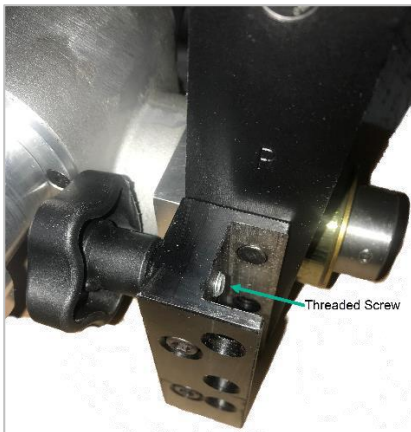

Rail Drill Rail Shoe Location



Properly Installed Rail Shoe

Rail Shoe Parts List

PART #	RAIL SHOES (QTY 2 PER DRILL)
465756	Shoe, Rail: 60 ASCE
714210	Shoe, Rail: 60 Kg UIC
465075	Shoe, Rail: 70 ASCE
714006	Shoe, Rail: 74 C
464770	Shoe, Rail: 75 ASCE
714055	Shoe, Rail: 75 BSR
714054	Shoe, Rail: 75 BSS
713969	Shoe, Rail: 78 NH
464771	Shoe, Rail: 80 ASCE
464983	Shoe, Rail: 85 ASCE
465076	Shoe, Rail: 85 PRR
465077	Shoe, Rail: 85 PS
464914	Shoe, Rail: 8520
713975	Shoe, Rail: 90 ARA-A
713974	Shoe, Rail: 90 ARA-B
714005	Shoe, Rail: 90 ASCE
464915	Shoe, Rail: 90 GN
465056	Shoe, Rail: 100 ARA-A
465083	Shoe, Rail: 100 ARA-B
465080	Shoe, Rail: 100 ASCE
714095	Shoe, Rail: 100 OH
465081	Shoe, Rail: 100 PS
465056	Shoe, Rail: 100 RA
714010	Shoe, Rail: 100 RE (AREA)
714100	Shoe, Rail: 100 RE (AREA) Head Free

PART #	RAIL SHOES (QTY 2 PER DRILL)
464946	Shoe, Rail: 105 Dudley
714103	Shoe, Rail: 105 OH
714085	Shoe, Rail: 107 NH
714009	Shoe, Rail: 110 RE (AREA)
714082	Shoe, Rail: 110 RE (AREA)
465057	Shoe, Rail: 112 RE (AREA)
714064*	Shoe, Rail: 115 RE (AREA) - *2-5/8" Hole Height
715149**	Shoe, Rail: 115 RE (AREA)- **2-7/8" Hole Height
714246	Shoe, Rail: 115 RE (AREA) For Guard Rail
715149	Shoe, Rail: 119 RE (AREA)
465348	Shoe, Rail: 122 CB
465082	Shoe, Rail: 127 Dudley
714248	Shoe, Rail: 130 HF
714249	Shoe, Rail: 130 RE (AREA)
464917	Shoe, Rail: 130 PS
714250	Shoe, Rail: 131 RE (AREA)
720265	Shoe, Rail: 132 RE (AREA)
714187	Shoe, Rail: 133 RE (AREA)
720265	Shoe, Rail: 136 RE (AREA)
720265	Shoe, Rail: 141 RE (AREA)
714287	Shoe, Rail: 140 RE (AREA)

Cutter Parts List

PART #	CUTTER BITS DIAMETER X DEPTH INCHES
464920	7/8" X 1"
473508	1" X 1"
473905	1-1/16" X 1"
472716	1-1/8" X 1"
473906	1-3/16" X 1"
473239	1-1/4" X 1"
473490	1-5/16" X 1"
473209	1-3/8" X 1"
473907	1-7/16" X 1"
473836	1-1/2" X 1"
475789	1-3/16" X 2"
313920	1" PILOT PIN
464754	2" PILOT PIN

Section 4: Maintenance

It is highly recommended to practice regular check-ups and maintenance in accordance with the usage frequency to keep your tool in better condition and reduces total running costs.



WARNING Do not perform maintenance on the machine while the hydraulic power source motor is running or when hoses are connected.

All maintenance must be done with the tool disconnected from the power source.

Cleaning and Maintenance Recommendations

- Wipe all external surfaces after each use with a clean, lint free cloth to remove surface contaminants from the tool.
- Store all tools in an enclosed area to prevent the weather from contaminating their systems.

Safety Devices

When maintenance is complete, make sure the following:

- The hydraulic control valves are operable.
- The hydraulic quick couplers and hoses are safe to use.

Storage Preparation

- Cover male and female hose whips.
- Store in the upright position. Secure tool to prevent it from being knocked over.
- Store the machine on a smooth level surface.
- The tool should be stored in a cool, dry environment which is not subjected to rapid temperature changes.

Daily



WARNING Do not attempt to locate hydraulic leaks by feeling around hoses and fitting with hand. Pin-Hole leaks can penetrate the skin.

- Wipe all tool surfaces, fittings, and couplings free of grease, dirt, and foreign materials.
- Inspect the tool, hydraulic system, hoses, and fittings for signs of leaks, cracks, wear, and/or damage. Replace if necessary.
- To prevent contamination, always install dust caps over the hydraulic ports when disconnected.
- Inspect machine for damage and wear, replace as required.

Monthly

- Perform a detailed inspection of the systems hoses and fittings according to the hydraulic hose operator's manual and as stated in SAE standard j1273, May 1989 or latest revision.

Replace the hoses and/or fittings if necessary.

Gearbox Oil Level

Check the gearbox oil level weekly

1. Remove the oil level plug (1).
2. Check that the oil level is up to the level of the bottom of the threaded hole.
If not, remove the vent pipe plug (2) and fill with the recommended oil.
3. The open end of the vent pipe is located within the lifting handle and should always be replaced in this position after filling.
4. Replace both plugs before use.

Maximum fill level of gearbox is 0.13 pints.

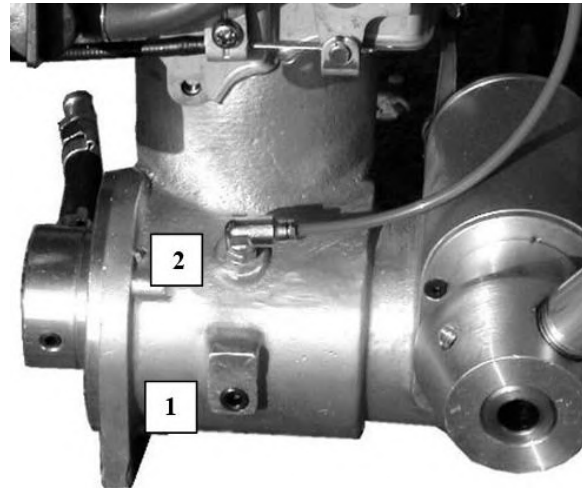

Hydraulic Maintenance

Wipe all external surfaces after each use with a clean, lint free cloth to remove surface contaminants from the tool.

The service life of the tool will be maximized by proper care and maintenance. The maintenance schedule below is recommended.

Daily

- Wipe all tool surfaces, fittings, and couplings free of grease, dirt, and foreign materials.
- Inspect the tool, hydraulic system, hoses, and fittings for signs of leaks, cracks, wear, and/or damage. Replace if necessary.
- To prevent contamination, always install dust caps over the hydraulic ports when disconnected.
- Inspect hydraulic hoses and couplings every day. Repair or replace if leakage, cracking, wear, or damage is evident.

Monthly

- Perform a detailed inspection of the system hoses and fittings according to the hydraulic hose operator's manual. Replace the hoses and/or fittings if necessary.
- Clean and repack impact hammer assembly with Mobil Delvac Xtreme Grease to insure proper lubrication.

Determining the Problem Area

1. Stop the power source.
2. Depressurize the system and allow to cool.
3. Disconnect the existing tool from the hoses and power source.
4. Stop the power source flow.
5. Disconnect the existing hoses from the known, properly operating tool and power source.
6. See the tool's operator manual for the correct disconnect Procedure.
7. Connect a different set of hoses to the known, properly operating tool and power source.
8. Start the power source flow.

If the known, properly operating tool operates with the different set of hoses, the problem is in the disconnected hoses.

If the known, properly operating tool does not operate, the problem is in the power source. See your power source operator's manual for troubleshooting.

If, after following all steps in the Troubleshooting section, it has been determined that the problem lies with the tool, proceed to the Troubleshooting Guide. The Troubleshooting Guide will help you identify and determine the cause of the problem.

Note: It is not recommended that the end-user attempt to perform repairs, as special tools and procedures are required.

Excess heat may be generated through any combination of pump inefficiencies, oil bypassing over relief valves, pre-existing flow controls, or unusual restrictions in the system. Where these and other possible inefficiencies exist, substantially larger reservoirs and/or coolers may be required.

Should you have any problems or questions with your Rail Drill, please do not hesitate to contact Racine Railroad Products.

Troubleshooting



Stop and depressurize the hydraulic system before connecting or disconnecting a tool. Failure to follow these instructions can lead to severe personal injury.

Read and follow the instructions in this manual for the proper way to connect and disconnect tools from the hydraulic system.

1. The tool must be connected to the correct power source system. Verify the hydraulic power source system matches the tool requirements.
2. Verify that the pressure and return hoses are connected properly to the tool and hydraulic power source ports.
3. The hydraulic power source reservoir must be filled to full level with hydraulic fluid.
4. After verifying the above, start the power source flow. All power sources shut-off devices must be engaged or opened (clutch engaged, separate ON/OFF valves open, etc.).
5. Check the tool to see if it operates

Note: If the tool does not operate, it will be necessary to determine where the problem exists (i.e., in the tool, hoses, or hydraulic power source).

Troubleshooting Guide

Symptom	Cause	Resolution
Tool will not operate.	Tool not properly connected	Check pressure and return conditions
	Low oil volume and/or pressure	Check hydraulic power source. Tool will not operate if inlet pressure is below 1000 psi or flow is less than 10 GPM
Tool runs at low speed.	Low oil volume and/or pressure	Check hydraulic power source for recommended flow, pressure, and proper conditions.
	Contaminated hydraulic system	Remove contamination and clean hydraulic system.
Oil leakage from trigger area.	Damaged O-rings in spool.	Replace O-rings. *Factory service is required.
Actuation Trigger sticks.	Excessive flow.	*Factory service is required. Check trigger, sleeve spool for binding.
	Broken spring.	Replace spring.
	Contamination.	Clean sleeve and spool. Check hydraulic system.

Troubleshooting Guide Continued

Symptom	Cause	Resolution
Tool trigger plunger sticks or works hard.	Check for dirt or deposits.	Clean components
	Trigger binding (trigger bent, trigger pivot pin to tight, etc.)	Inspect, adjust trigger where binding occurs.
System overheats.	Excessive flow.	Reduce RPM of engine.
	Inefficient cooling.	Increase reservoir size and/or oil cooler.
Too leaks hydraulic fluid. WARNING: Do not use tool. Tool with leak may cause bodily injury.	Tool components loose.	Factory service may be required. Tighten component hardware.
	Damaged O-rings or gaskets.	Replace worn or damaged O-rings or gaskets.
	Incorrect grease used in nose housing.	Remove nose assembly, clean components, and repack with appropriate grease.
	Tool components worn or damaged.	Disassemble tool. Replace worn or damaged components.
Power source works but tool lacks power or does not operate.	Inappropriate hydraulic system.	Check type of hydraulic power source, open-center, or closed-center.

Section 5: Parts and Service Support

Technical Support & Service

Telephone and web-based technical support is available for current production models through our Customer Service Department. Service Manuals and limited technical support may be available for models that are no longer in production.

Telephone and E-mail Technical Support

Telephone and e-mail technical support is available on normal U.S. business days from 8:00 AM to 5:00 PM U.S. Central Time Zone (GMT +6 (+5 Daylight Savings Time)).



1955 Norwood Court
Mount Pleasant, WI 53403
Phone: (262) 637-9681
Email: custserv@racinerailroad.com
racinerailroad.com



Unit 3 Hartington Industrial Estate
Chesterfield • Derbyshire, S43 3YF
Phone: 0330 164 1375
Email: info@racinerailroad.co.uk
racinerailroad.co.uk

Non-Warranty Technical Support

Depending upon the circumstances and availability of technical service personnel, we may provide technical assistance and/or field service support, *at the customer's expense*, to assist in the correction of non-warranty related problems. Contact our Customer Service Department to coordinate Non-Warranty Technical or Field Service Support.

Warranty Support Technical Support

Depending upon the circumstances and availability of technical service personnel, we may provide technical assistance and/or field service support, *at no charge to the customer*, to assist in the correction of warranty related problems. Contact our Customer Service Department to coordinate Warranty Technical or Field Service Support.

Warranty Parts Claims

Material claimed to be defective must be returned to our factory for evaluation. Defective materials will be replaced, or your account will be credited if replacement materials have already been purchased. Please contact our Customer Service Department at the address provided below if you have any questions or problems.

Warranty Service Support

Depending upon the circumstances and availability of technical service personnel, we may provide technical assistance and/or field service support, *at no charge to the customer*, to assist in the correction of warranty related problems. Contact our Customer Service Department at the address provided above to coordinate Warranty Service Support.

FOR SERVICE ONLY

QTY	DESCRIPTION	PART NO.
REF	PIPE, VENT	475584
REF	ELBOW, .12 BSP	475585
REF	HANDLE, HYDRAULIC RAIL	475586
REF	MOTOR, HYDRAULIC	475587
REF	KIT, H36RAIL HYDRAULIC PIPE	475588
REF	SCR, M5 X 40	475589
REF	SCR, SOC SET: M8 X 20	475591
REF	ARM, CAPSTAN	475592
REF	GRIP, HAND	475593
REF	KNOB, CAPSTAN	475594
REF	SPINDLE, CAPSTAN	475595

Arbor Spindle Assembly and Parts List

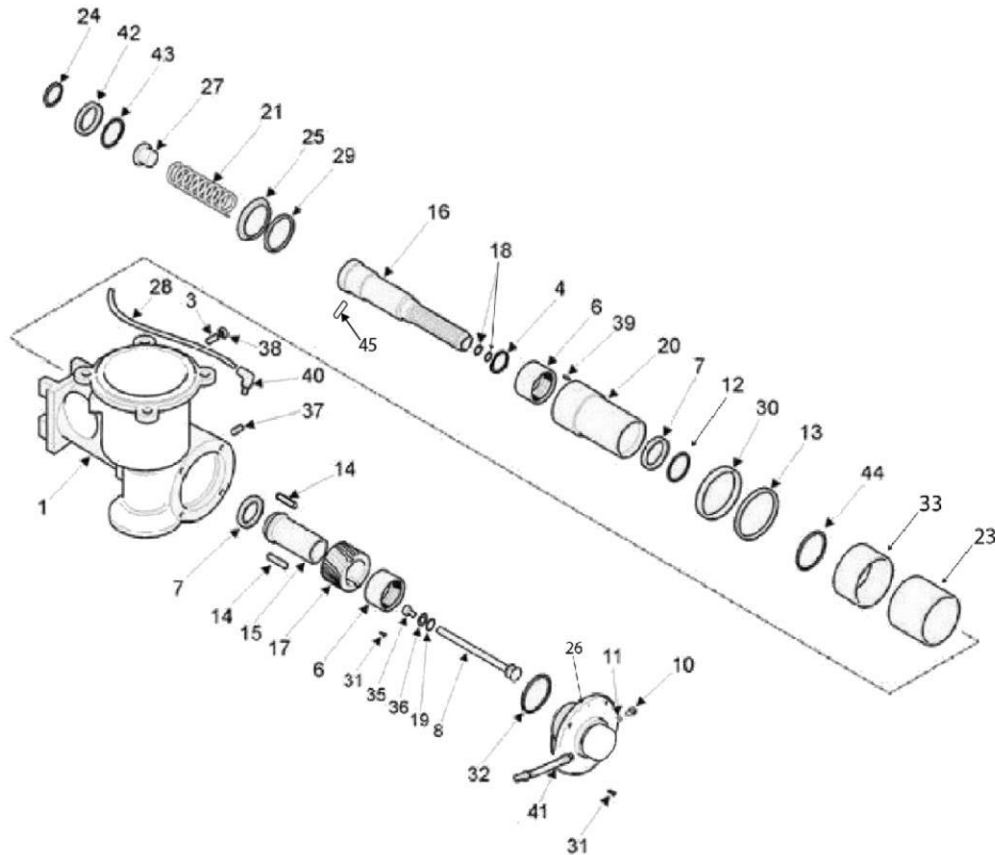

Item	Description	Quantity	Item	Description	Quantity
1*	MAIN HOUSING	1	25	FEED RACK WEAR CAP	1
2	M4 SHAKEPROOF WASHER	4	26	COOLANT HOUSING END CAP	1
3	M8 DOGPOINT SOCKET SCREW	1	27	BUTTON	1
4	CIRCLIP	1	28	VENT PIPE	1
6	COMBINED NEEDLE THRUST RACE	2	29	OIL SEAL	1
7	BEARING	2	30*	OIL SEAL PROTECTION RING	1
8	COOLANT FEED TUBE	1	31	M4 x12 STAINLESSS CAP SCREW	4
10	COOLANT TUBE CLAMP SCREW	1	32	O RING	1
11	O RING	1	33*	BRONZE FRONT BUSH	1
12	CIRCLIP	1	35	M8 X 15 CAP SCREW	1
13	OIL SEAL	1	36	M8 WASHER	1
14	FINAL DRIVE KEY	2	37	1/8" BSPT PLUG	1
15	FINAL DRIVE SPINDLE	1	38	M8 HEX NUT	1
16	ARBOR SPINDLE	1	39	ROLL PIN	1
17	WORM AND GEAR	1	40	1/8" BSP ELBOW	1
18	O RING	2	41	COOLANT HOSE ASSEMBLY	1
19	O RING	1	42	SEAL	1
20	FEED RACK	1	43	WASHER	1
21	SPRING	1	44	O RING	1
23*	BRONZE REAR BUSH	1	45	ARBOR PIN	1
24	CIRCLIP	1			

Arbor / Spindle Drive Assembly and Parts List

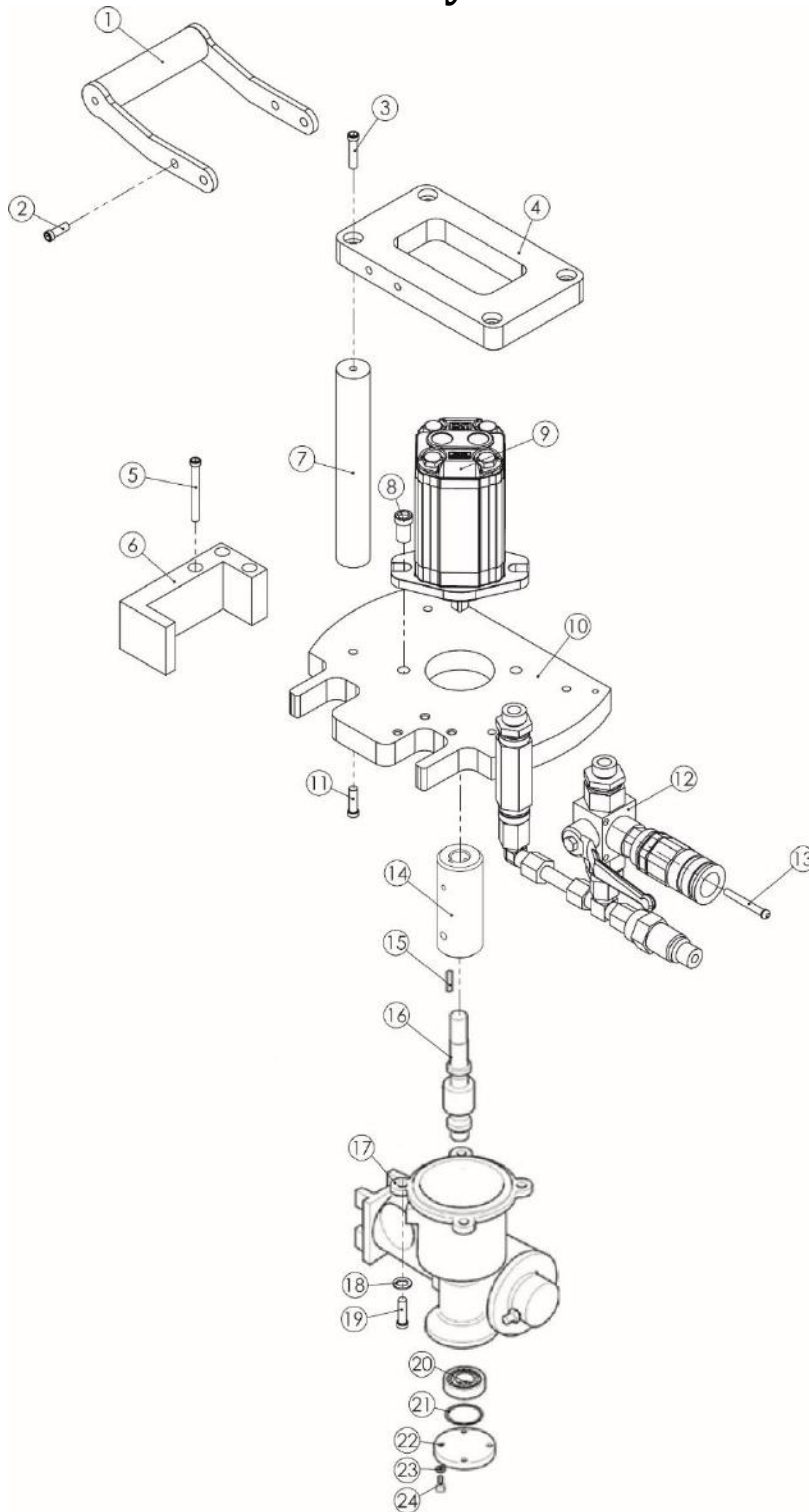

Arbor / Spindle Drive Assembly Parts List

Item	Description	QTY
1	HYDRAULIC RAIL HANDLE ASSEMBLY	1
2	M6 X 16	4
3	M6 X 25	4
4	MOTOR CAGE TOP	1
5	M6 X 50	3
6	HYDRAULIC FEED BLOCK	1
7	MOTOR CAGE LEGS	4
8	M10 X 16	2
9	HYDRAULIC MOTOR	1
10	MOTOR CAGE BASE	1
11	M6 X 20	4
12	H36RAIL HYDRAULIC PIPE KIT	1
13	M5 X 40	2
14	CONNECTION SHAFT	1
15	KEY	1
16	GEAR SET	1
17	MAIN HOUSING	1
18	M6 SHAKEPROOF WASHER	4
19	M6 X 20	4
20	BEARING	1
21	O'RING	1
22	SHAFT COVER	1
23	M4 SHAKEPROOF WASHER	4
24	M4 SHCS	4

Arbor Spindle Feed Assembly and Parts List

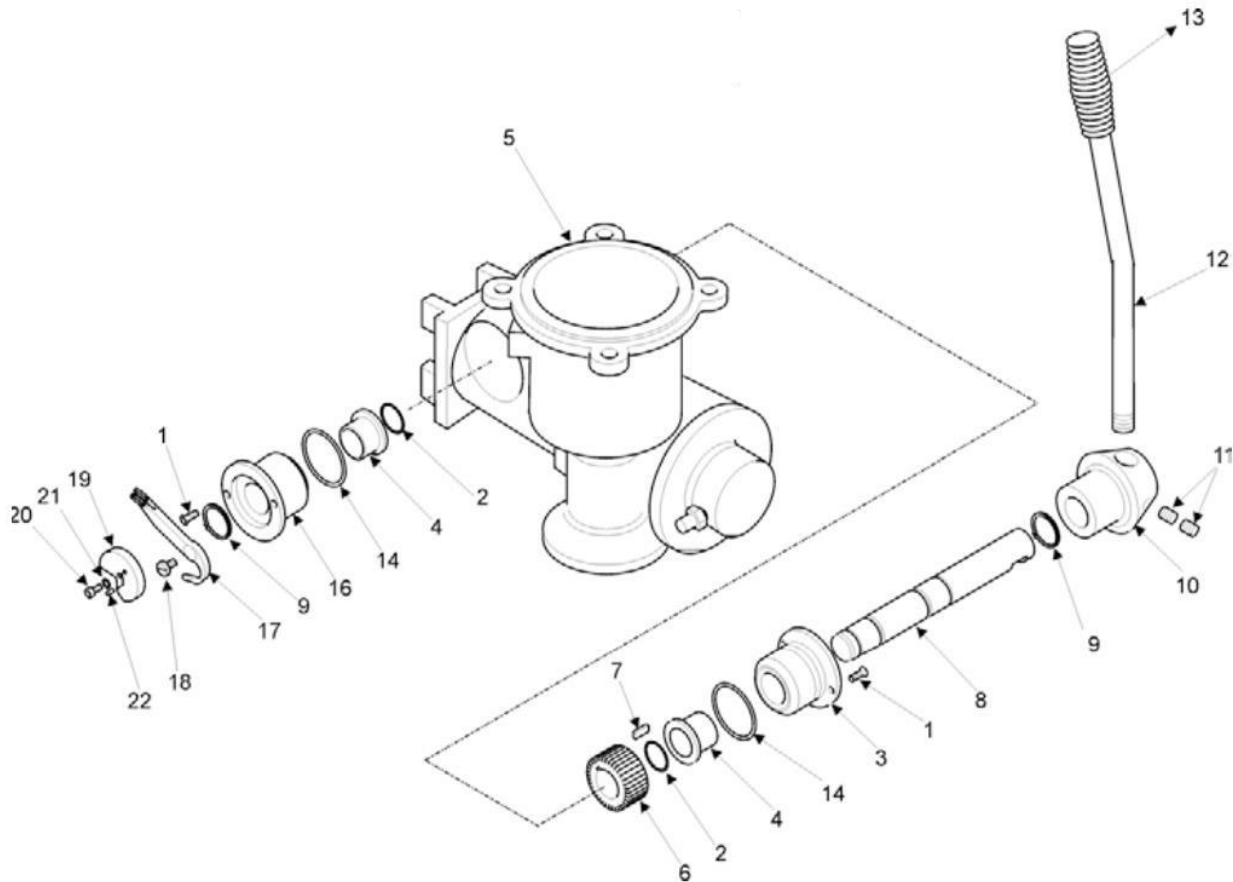

Item	Description	QTY
1	M4 CSINK SET SCREW	3
2	O' RING	2
3	CAPSTAN SPINDLE HOUSING	1
4	FLANGED OILITE BUSH	2
5	MAIN HOUSING	1
6	FEED GEAR	1
7	FEED GEAR KEY	1
8	CAPSTAN SPINDLE	1
9	CIRCLIP	2
10	CAPSTAN HUB	1

Item	Description	QTY
11	M8 x 20 DOGPOINT SOCKET SCREW	1
12	CAPSTAN ARM	1
13	HAND GRIP	1
14	O' RING	2
16	CAPSTAN SPINDLE HOUSING	1
17	THROTTLE LINK	1
18	THROTTLE LINK PIVOT	1
19	THROTTLE CAM	1
21	SHCS M5	1
22	3 DIA ROLL PIN	1

Rail Clamp Assembly and Parts List

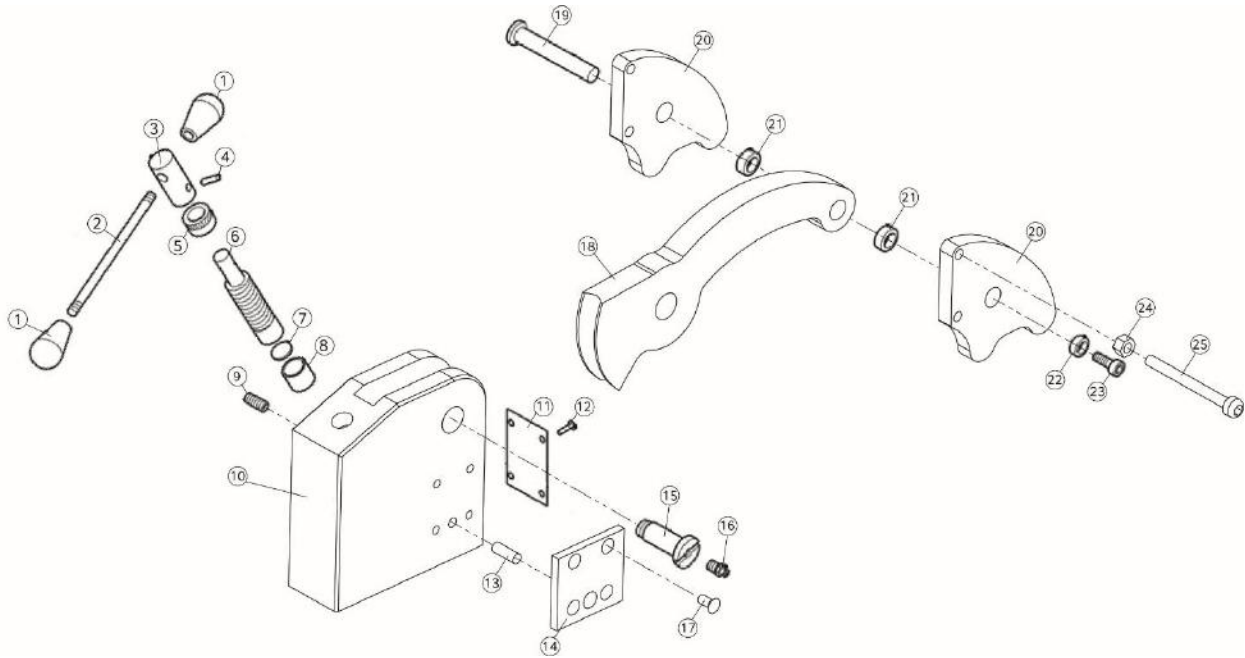

Item	Description	QTY
1	CAPSTAN KNOB	2
2	CAPSTAN SPINDLE	1
3	CAPSTAN	1
4	M5 x 20 SOCKET SCREW	1
5	COLLAR	1
6	WORM	1
7	THRUST WASHER	1
8	BEARING BUSH	1
9	LOCK SCREW	1
10	CLAMP BODY	1
11	GUARD PLATE	1
12	RIVET	4

Item	Description	QTY
13	ROLL PIN	1
14	SHIM PLATE	2
15	PIVOT PIN	1
16	LUBRICATION NIPPLE	1
17	COUNTERSUNK SCREW	8
18	CLAMP ARM	1
19	ROLLER PIN	1
20	RAIL CLAMP FOOT	2
21	DISTANCE PIECE	2
22	COLLAR	1
23	SCREW	1
24	M6 NUT	2
25	M6 x 65 BUTTON HEAD	2

Section 6: Warranty Terms and Conditions

Warranty Period

Each new machine and new parts of our manufacture are warranted against defects in material and workmanship for one year from the date of shipment from our factory.

When contacting customer service for factory parts, service or warranty support please provide the:

- Racine Railroad Products Model
- Serial Number
- Any locally assigned identification

Vendor Parts Warranty Period

Other equipment and parts used, but not manufactured by Racine Railroad Products, Inc., are covered directly by the manufacturer's warranty for their products.

Warranty Parts and Service

We will repair or replace, without charge, F.O.B. factory, Racine, Wisconsin, USA, any part Racine Railroad Products manufactures which is proven to be defective during the warranty period.

Material claimed defective must be returned, if requested, to the factory within 30 days from the date of the claim for replacement. Ordinary wear and tear, abuse, misuse, and neglect are not covered by this warranty. Depending upon the circumstances, we may provide technical assistance and/or technical service support, without charge, to assist in the correction of warranty related problems.

Non-Warranty Parts and Service

Material damaged through normal wear and tear, abuse, misuse and/or neglect are not covered by our warranty and should be ordered directly from Customer Service.

Note: Parts for models that are no longer in production may not be available.

Non-Warranty Parts Orders

When placing a parts order please provide the following information:

- Company Name and Billing Address
- Purchase Order Number and Issuing Authority
- Shipping Address
- Special Handling Instructions
- Contact Phone Number
- Machine Model and Serial Number
- Part Numbers and Quantities Being Ordered

Note: Please use Racine Railroad Products part numbers when ordering parts. Racine Railroad Products part numbers are shown in the parts lists and drawings of this manual and have only six (6) numbers.

Any part number with other than six numbers (e.g., contains alpha-numeric characters) is a Vendor Part Number and **not** a Racine Railroad Products part number